

Dell XC430 Web-Scale Converged Appliance Solutions Guide



Notes, cautions, and warnings

 **NOTE:** A NOTE indicates important information that helps you make better use of your computer.

 **CAUTION:** A CAUTION indicates either potential damage to hardware or loss of data and tells you how to avoid the problem.

 **WARNING:** A WARNING indicates a potential for property damage, personal injury, or death.

Copyright © 2015 Dell Inc. All rights reserved. This product is protected by U.S. and international copyright and intellectual property laws. Dell™ and the Dell logo are trademarks of Dell Inc. in the United States and/or other jurisdictions. All other marks and names mentioned herein may be trademarks of their respective companies.

2015-09

Rev. A00

Contents

1 About Dell Web-Scale Converged Appliance solution.....	5
2 Supported hardware, firmware, and software.....	6
3 Documentation matrix.....	7
Dell documentation.....	7
Nutanix documentation.....	8
4 Licensing overview.....	10
Starter license.....	10
Pro and Ultimate licenses.....	10
Setting up Nutanix Customer Portal.....	10
License management.....	11
5 Deploying your system.....	12
Before you begin.....	12
Setting up your Dell XC430 for first use.....	12
Boot error message for missing SD card.....	13
Deployment outline.....	13
Default cluster credentials.....	15
6 Downloading and installing Software applications.....	17
OpenManage Essentials.....	17
Installing Dell OpenManage Essentials on a separate server.....	17
Dell Nautilus	18
7 Monitoring.....	19
Monitoring software.....	19
8 Updating firmware.....	21
Updating drive firmware with Dell Nautilus.....	21
9 Replacing hardware.....	23
Replacing components with no cluster data.....	23
Replacing failed front HDD and SSD components that contain cluster data.....	23
10 Recovering system.....	25
11 Getting help.....	26

Contacting Dell.....	26
Locating Service Tag.....	26
Quick Resource Locator	26

About Dell Web-Scale Converged Appliance solution

Dell provides a web-scale converged appliance solution that includes the Dell XC430 server and software from Nutanix (used as a virtual appliance), which simplifies virtualization by converging computer, storage, and network into a single appliance that is deployed in a clustered environment. The following figures show Dell XC430. For more information about the Dell XC430 system, see *Dell XC430 Owner's Manual* available at Dell.com/xcseriesmanuals.



Figure 1. Front view of Dell XC430—four slots



Figure 2. Rear view of Dell XC430

Supported hardware, firmware, and software

For a list of the most up-to-date supported hardware, firmware, and software, see the *Dell XC430 Web-Scale Converged Appliance Support Matrix* available at [Dell.com/xcseriesmanuals](https://www.dell.com/xcseriesmanuals).

Documentation matrix

The documentation matrix provides information about the documents you use to configure and deploy the Dell web-scale converged appliance solution.

 **WARNING:** See the safety and regulatory information that shipped with your system. Warranty information may be included with this document or as a separate document.

Make sure that you read through any media that ships with your system that provides documentation and tools for configuring and managing your system, including those pertaining to the OS, system management software, system updates, and system components that you purchased with your system.

 **NOTE:** URLs such as **Dell.com/support** or **Dell.com/support/home**, are not active, because you must type the URL from your location to access your specific language.

For the full name of an abbreviation or acronym used in this document, see the Glossary at **Dell.com/support/home**.

 **NOTE:** Always check for updates on **Dell.com/support/home** and read through the updates first, because they often supersede information in other documents.

 **NOTE:** While upgrading your system, Dell recommends that you download and install the latest BIOS, driver, and systems management firmware on your system from **Dell.com/support/home**.

Dell documentation

Dell documentation is either included with your shipment or available at **Dell.com/xcseriesmanuals**.

Dell documentation for:

- Dell iDRAC (integrated Dell Remote Access Controller) is available at **Dell.com/esmanuals**.
- Dell OpenManage Essentials is available at **Dell.com/openmanagemanuals**.

To access Dell documentation:

1. Go to **Dell.com/support/home**.
2. Click **View Products**, and then click **Servers, Storage & Networking**.
3. Click **Engineered Solutions** → **Dell XC Web-Scale Converged Appliances**, and then select the documentation you require.

Table 1. Dell reference documentation for the Dell XC430 Web-Scale Converged Appliance

To learn about...	See...
Set up instructions of your Dell XC430, including the technical specifications	<i>Getting Started Guide</i>
Hardware details of your Dell XC430	<i>Owner's Manual</i>
Installing your Dell XC430 in a rack	<i>Dell Rack Install Guide</i>
Deploying and setting up this solution	<i>Solutions Guide</i>
Setting up and using Dell iDRAC8	<i>Dell iDRAC8 Quick Start Guide</i>
Using OpenManage Essentials to monitor, perform updates, view hardware, and view inventory on your system	<i>Dell OpenManage Essentials User's Guide</i>
List the supported hardware, firmware, and software for the Dell XC430 Series appliances.	<i>Dell XC430 Web-Scale Converged Appliance Support Matrix</i>

Nutanix documentation

Most Nutanix documentation is available at <https://portal.nutanix.com/#/page/docs> on the **Nutanix Documents** page. However, two documents are available behind the Nutanix document portal. Nutanix documentation is listed by version, category, and type. Make sure that you select the appropriate version of documentation for this release, which is 4.1 or later. Or, see the Nutanix OS to find corresponding documentation support.

To access most Nutanix documentation:

1. Go to <https://portal.nutanix.com/#/page/docs>.
2. Select the documentation you require from the list specified in Table 10.

 **NOTE:** To access the *Hardware Replacement Documentation* by using the open document portal, use the **Filter By** controls in the upper-right corner of the page. Select **NOS, 4.1**, and XC430 to view this document.

To view the *NOS Advanced Administration Guide* and *Advanced Setup Guide*:

1. Go to <https://portal.nutanix.com/#login>.
2. Log in to your portal and select **Documentation**.
3. On the **Nutanix Documents** page, select the documentation you require.

Table 2. Nutanix reference documentation

To learn about...	See...
Set up instructions for your solution.	<i>Setup Guide</i>
Set up instructions for environments with special requirements and restrictions	<i>Advanced Setup Guide</i>
Instructions and reference for administering the Nutanix Operation System (NOS) outside the Nutanix Prism UI (such as cluster start/stop, manual upgrade, changing passwords, reconfiguring IP addresses, and troubleshooting tools).	<i>NOS Advanced Administration Guide</i>
Comprehensive instructions and references for the Nutanix UI, including overview information.	<i>Web Console Guide</i>
Managing KVM Nutanix Acropolis hosts that run NOS.	<i>Acropolis Virtualization Administration Guide</i>
Managing KVM Nutanix Acropolis hosts that run NOS.	<i>Acropolis Virtualization Administration Guide</i>
Managing KVM Nutanix Acropolis hosts that run NOS.	<i>Acropolis Virtualization Administration Guide</i>
Managing Hyper-V hosts that run NOS, including domain requirements.	<i>Hyper-V Administration Guide</i>
Comprehensive references for the Nutanix REST API.	<i>API Reference</i>
Comprehensive references for Controller Virtual Machine (CVM) utilities, nCLI commands, and Nutanix PowerShell cmdlet.	<i>Command Reference</i>
Software instructions for hardware components that are not functioning.	<i>Hardware Replacement Documentation</i>

Licensing overview

The Nutanix virtual computing platform includes various features to enable you to administer your environment according to your current and future requirements. You can use the default feature set of Nutanix Operating System (NOS), upgrade to an enhanced feature set, update your license for a longer term, or reassign existing licenses to nodes or clusters as required.

Starter license

Each Nutanix node and block is delivered with a default Starter license, which is issued for a six-year term that begins at the shipping date for your Dell XC430 order. You are not required to register this license on the Nutanix Customer Portal account assigned to you when you purchased your nodes.

Pro and Ultimate licenses

The Pro and Ultimate license types require you to download a license file from the Nutanix Customer Support Portal and install it on your cluster. When you upgrade to a Pro or Ultimate license, or add nodes or clusters to your environment with these licensed features, you must generate the license file, download it, and then install it.

 **NOTE:** The most current information about your license is available at the Nutanix Customer Support Portal. You can view information about license types, expiration dates, and any free license inventory (that is, unassigned available licenses).

Setting up Nutanix Customer Portal

If you are new to Nutanix Support, create a personal profile on the Nutanix Customer Portal. Creating a personal profile allows you to manage your licenses.

 **NOTE:** The Nutanix Customer Portal is also required to access some of the advanced Nutanix documentation.

To set up your Nutanix Customer Portal, complete the following tasks:

1. Go to the Nutanix Customer Portal at <http://portal.nutanix.com> and click **Register Now**.
2. Register by typing data in appropriate boxes.
3. In the **Serial Number** box, type the Service Tag number of your Dell XC430 system.

 **NOTE:** To find the Service Tag of your Dell XC430, see the Locating The Service Tag section in this document.

4. After the Customer Portal account is created, you can manage your licenses.







License management

For more information about license management, complete the following tasks:

1. On the Nutanix Documentation portal, see the *Web Console Guide* (for access details, see the [Documentation matrix](#) section in this document).
2. In the Nutanix *Web Console Guide*, see the *License Management* section.
3. Perform the relevant licensing tasks for your system.

Deploying your system

Before you deploy your system, ensure that you read through this document and have yourself familiarized with the process and required materials.

-  **WARNING:** Before you set up and operate your Dell XC430, review the safety instructions that shipped with your storage enclosure.
-  **WARNING:** The weight of your system without the physical disk drives installed (empty weight) is 16.73 kg (36.88 lb).
-  **WARNING:** Your system must be installed by Dell certified service technicians.
-  **CAUTION:** Before installing your system in the rack, make sure that the weight of the system does not exceed the weight limit of the rack. For more information, see the Rack Installation instructions that shipped with your system.
-  **NOTE:** For weight stability, always load the rack by using bottom-up approach.
-  **NOTE:** This solution is deployed by Dell Services. The following deployment steps provide an outline of what Dell Services accomplishes during the deployment process.

Before you begin

-  **CAUTION:** It is important that you perform all the steps in this guide prior to doing other configuration steps.

Make sure that the following items are available:

- Power cables
 - Network cables — optical and/or copper (Intel SFP+ or Category 6 Ethernet)
 - Rail kit
 - Nutanix documentation — *Setup Guide* and *Advanced Setup Guide*
 - Dell Documentation — *Dell XC430 Web-Scale Converged Appliance getting Started Guide*, *Dell XC430 Web-Scale Converged Appliance Solutions Guide*, *Rack Installation Instructions*, and *Safety Instructions*, and *Dell XC430 Web-Scale Converged Appliance Support Matrix*.
-  **NOTE:** For information about locating required documents, see the [Documentation matrix](#) section in this document.

Setting up your Dell XC430 for first use

1. Make sure that your system components are properly installed.

Your system is shipped with physical disk drives, power supply units (PSUs), and fan components already installed. Ensure that all components are properly seated and have not become dislodged and/or damaged during shipping.

2. Install the Dell XC430 in a rack.

The Dell XC430 requires a compatible rack and a rack installation kit. For information about installing the rails for the Dell XC430, see the *Rack Installation Instructions Guide* that shipped with your system.

3. Cable your solution based on best practices cabling diagram shown here.

 **NOTE:** At a minimum, there are three Dell XC430 servers in a cluster. Each Dell XC430 is seen as a node.

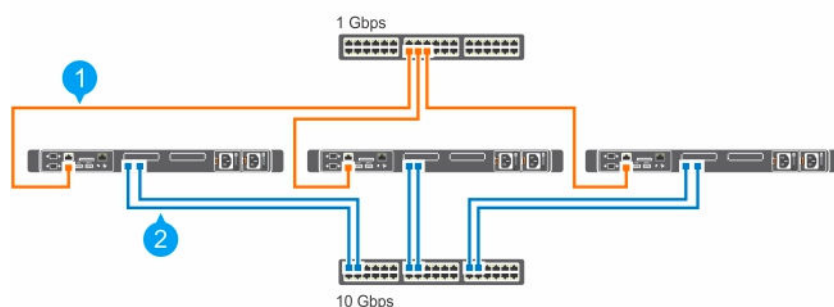



Figure 3. Cabling a system

1. Management Network
2. Host Network

 **NOTE:** The preferred (best practice) setup is to connect the management port across all three nodes to the same switch (management network).

Boot error message for missing SD card

The XC430 system has only one SD card. When you start the system, the following error message is displayed:

```
The secondary SD card is missing, not responding, or in write-protected mode.  
Do one of the following:
```

1. Install an SD card media in the secondary SD card slot.
2. Reseat or replace the SD card media.
3. If the secondary SD card is intentionally not installed or write-protected mode is expected, then no response is required.

The message is a known issue and you must ignore it.

Deployment outline

The flow of tasks in deploying the XC Series Web-Scale Converged Appliance is shown here.

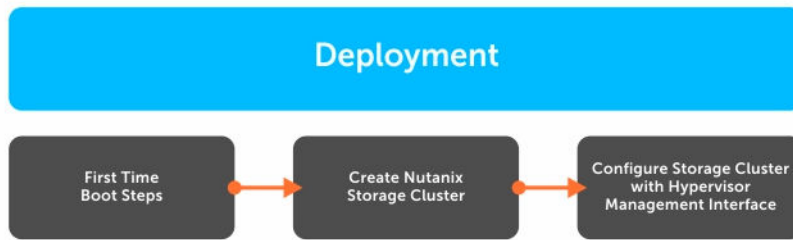

Figure 4. Deployment workflow process.

First time boot scripts

Nutanix Acropolis nodes have been pre-configured and do not require additional first time boot configuration. These nodes boot to the hypervisor and are ready to be clustered once the CVM has all services up.

Run the VMware vSphere first boot scripts on every node after they are properly racked and cabled. The first time boot scripts accomplish the following tasks:

NOTE: These first time boot scripts run automatically upon the first boot of the system and include multiple reboots.

- Creates vSwitch Nutanix, internal and external port groups and vmkernel interface with address on internal portgroup.
- Activates vMotion and management on the default external vmkernel interface (vmk0).
- Enables TSM-SSH and TSM and allows sshClient, nfsClient, and ntpClient through the firewall.
- Denies vprobeServer through the firewall.
- Sets advanced ESXi parameters.
- Enables auto-start, sets the default RAM, and number of vCPU for the CVM.
- Elects applicable data-disk storage controller for PCI pass-through.
- Disables drivers associated with pass-through storage controllers.
- Installs the following VIBs: Nutanix VAAI, updated ixgbe and igb driver, and GPU VIBs (if applicable).
- Renames local VMFS datastore to standard naming convention: NTNX-local-ds-<block id>-<node_position>.
- Starts CVM and check for the existence of /tmp/svm_boot_succeeded.
- Restart host.

Complete the Microsoft Hyper-V First boot scripts on every node after they are properly racked and cabled. The first time boot scripts accomplish the following tasks:

NOTE: These first time boot scripts are run from a first time boot scripts wizard and require minimal user intervention.

- Sets up vSwitch or LBFO NIC Team
- Installs NIC drivers (Intel), Cygwin, ipmiutil, and Python
- Registers CVM as a VM
- Attaches Disks to CVM
- Enables auto-start, sets the default RAM and number of vCPU for the CVM.
- Starts CVM and checks for the existence of /tmp/svm_boot_succeeded
- Restarts host

Create Nutanix storage cluster

- Use the Nutanix web-based clustering application to create Nutanix storage cluster from all locally discovered nodes ready to be clustered. During this process, the following parameters are set:
 - Cluster name
 - Set cluster IPs (iDRAC, Hypervisor, and CVM)
 - Cluster virtual external IP
 - Subnet mask and default gateway, and cluster virtual external IP
 - DNS and NTP (hypervisor NTP N/A for Hyper-V) servers
- Option to create Nutanix storage cluster manually, if IPv6 link-local is not enabled

Configure Nutanix storage cluster using hypervisor management GUI

KVM Nutanix Acropolis:

- Create storage pool and containers through Nutanix web console.
- Create, deploy, and manage virtual machines through Nutanix web console.
- For more information, see the *Acropolis Virtualization Administration Guide*.

VMware vSphere:

- Create storage pool through Nutanix web console.
- Create and mount containers as NFS datastores on appropriate hosts through Nutanix web console.
- Manually add and configure vSphere cluster by using the Nutanix guidelines. For more information, refer to the *vSphere Administration Guide*.

Microsoft Hyper-V:

- Create storage pool and containers through Nutanix web console.
- Run Hyper-V setup script from any CVM to join hosts to domain, create Hyper-V failover cluster, and register storage cluster as SMB share.
- Optionally, add cluster to System Center Virtual Machine Manager with Hyper-V setup script or manually.

Default cluster credentials

The default cluster credentials for the system differ from those provided at the starting of all Nutanix documentation. See Table 3 for default cluster credentials, which are specific to the system.

 **NOTE:** The default password is not set for ESXi hosts.

Table 3. Default Cluster Credentials

Interface	Target	Username	Password
Web management console	iDRAC	root	Calvin
Remote desktop or console	Hyper-V host	Administrator	nutanix/4u

Interface	Target	Username	Password
SSH client or console	KVM host	root	nutanix/4u
SSH client or console	ESXi host	root	
SSH client	Nutanix Controller VM	nutanix	nutanix/4u
Nutanix Web Console	PRISM Interface (after cluster configuration)	admin	admin

 **NOTE:** Default password applies for Nutanix Web Console prior to NOS 4.1.3. For 4.1.3 and later, you must set a new admin password on first login.

Downloading and installing Software applications

OpenManage Essentials

OpenManage Essentials is a hardware management application on a separate server that provides a comprehensive view of the Dell XC430 and its components. OpenManage Essentials enables you to:

- Discover and list the system inventory
- Monitor the health of a system
- Perform system updates and remote tasks
- View hardware inventory and compliance reports

For information about the supported OpenManage Essentials versions, see the Supported hardware, firmware, and software section in this document.

To download OpenManage Essentials management software, go to **Dell.com/support/home** or the Dell TechCenter website at **DellTechCenter.com/OME**.

To download the *OpenManage Essentials User's Guide*, go to **Dell.com/openmanagemanuals**.

 **NOTE:** To install OpenManage Essentials, you must have local system administrator privileges, and the system you are using must meet the criteria mentioned in the Installation Prerequisites and Minimum Requirements section of the *OpenManage Essentials User's Guide*.

 **NOTE:** OpenManage Essentials must be installed on the management network or a network that has access to the IMPI or iDRAC ports.

Installing Dell OpenManage Essentials on a separate server

To install OpenManage Essentials:

1. Go to **Dell.com/openmanagemanuals** and open the *OpenManage Essentials User's Guide*.
2. Go to the Installation Prerequisites and Minimum Requirements section and complete the tasks as described.
3. Go to the Installing OpenManage Essentials section and complete the tasks as described.
4. Install the following optional software applications:
 - Dell OpenManage Essentials
 - Dell Repository Manager

 **NOTE:** Install Dell Repository Manager only if you want to customize the Firmware Bundles and Update Packages.

- Documentation

Dell Nautilus

Dell Nautilus is a general maintenance release utility for updating firmware for SAS and SATA drives (or disks).

For information about the supported Dell Nautilus version number, see the Supported hardware, firmware, and software section in this document.

To download the Dell Nautilus Firmware Update Utility for SAS and SATA disk Solid State Drives (SSDs):

1. Go to **Dell.com/support/drivers**.
2. Under the **Customized support** section, in the **Enter your Service Tag or Express Service Code** box, type the Service Tag of your Dell XC430, and then click **Submit**.
 **NOTE:** If you do not have a Service Tag, select **Detect My Product** to allow the system to automatically detect your Service Tag, or select **Choose from a list of all Dell products** to select your product from the **Product Selection** page.
3. On the **Product Support** page, click **Drivers & downloads**.
4. From the **Operating System** drop-down menu, select **Not Applicable**.
5. Go to the **SAS Drive** section.
6. Search for Dell Nautilus Firmware Utility for SAS and SATA disk and SSDs.
7. Click **Download**. Click **Download** again to download the .exe file. In your Download folder, locate the latest version of Dell Nautilus and click to expand the compressed files.
8. In the extracted folder, run the USBMake Utility.
9. Create the bootable Nautilus package and perform one of the following tasks:
 - To create a bootable CD or DVD image (ISO), click Create Bootable CD Image and follow instructions. Burn the .iso image file to CD or save the bootable ISO on a management workstation.
 - Connect a USB flash drive to the system and follow instructions to create a bootable USB flash drive.

Monitoring

Table 4. System component monitoring guide

System Components	Monitor Utility
System memory	Dell OpenManage Essentials
Cooling fans	Dell OpenManage Essentials
Network Daughter Card	Dell OpenManage Essentials
Processors	Dell OpenManage Essentials
PSUs	Dell OpenManage Essentials
NIC	Dell OpenManage Essentials
H730 Mini	Dell OpenManage Essentials
Front HDDs	Nutanix web console
Front SSDs	Nutanix web console

 **NOTE:** For instructions about using Dell OpenManage Essentials to monitor the Dell XC430 system, do the following:

1. See the *OpenManage Essentials User's Guide*.
2. For information about discovering components of a Dell XC430 system, see the Discovering and Inventorying Devices section.
3. To use the functionality of OMSA preinstalled on each node, configure it by using the *OpenManage Essentials User's Guide*.
4. To add Dell XC430 to the discovered list of systems, discover Dell XC430 by using an IP range.

Monitoring software

To monitor the health of a cluster, VMs, performance, and alerts and events, the Nutanix web console provides a range of status-check features.

For more information about monitoring with the Nutanix web console, view the *Web Console Guide* document on the Nutanix documentation portal (for more information, see [Documentation matrix](#) section in this document).

In the *Nutanix Web Console Guide* document, see the following sections:

- Health Monitoring
- Virtual Machine Monitoring
- Performance Monitoring
- Alert and Event Monitoring

Updating firmware

Table 5. System component update guide

System components	Utility
Network Daughter Card	Dell OpenManage Essentials
PSUs	Dell OpenManage Essentials
NIC	Dell OpenManage Essentials
BIOS	Dell OpenManage Essentials
iDRAC	Dell OpenManage Essentials
Dell PERC	Dell OpenManage Essentials
Front HDDs	Nutanix web console
Front SSDs	Nutanix web console
SATADOM	Contact Dell Support

Use Dell OpenManage Essentials to update the firmware of the discovered system components. For instructions about using Dell OpenManage Essentials to monitor and update the discovered components of the Dell XC430 system, see *Updating Server BIOS, Firmware, Drivers, and Applications* in the *OpenManage Essentials User's Guide*.

 **NOTE:** Dell Nautilus may be used as an alternative to the Nutanix web console for updating firmware of the front HDDs and SSDs.

Updating drive firmware with Dell Nautilus

To update disk firmware with Dell Nautilus:

1. Turn off Controller Virtual Machine (CVM).
For information about how to turn off a node, see the *Nutanix Hardware Replacement* document.
2. Put hypervisor in Maintenance mode.
3. Access system GUI, and do one of the following:
 - Connect the physical keyboard or monitor or mouse to the ports on the Dell XC430.
 - Connect to the iDRAC GUI.

 **NOTE:** For information about configuring and accessing the iDRAC GUI, see the *iDRAC Quick Start Guide* at Dell.com/support/home.

4. Mount the Dell Nautilus ISO or the USB key to the system using virtual media.
5. While restarting the server, press F11 to open BIOS boot manager.
6. From the list, select **EFI Boot Manager**.
7. From the **EFI boot** list, select **Virtual CD** or the **USB drive**.
8. To update drive firmware, click **Update Firmware**.

 **NOTE:** Dell Nautilus updates all HDD and SSD firmware for all HDDs and SSDs connected to the system.

Replacing hardware

This section describes high-level tasks to replace components correctly within the Dell XC430 solution.

Before you begin, for information about downloading the following required documents for the three hardware replacement tasks, see the [Documentation matrix](#) section in this document. The documents are:

- *Hardware Replacement Documentation*
- *Dell XC430 Owner's Manual*

After you have these documents, you are ready to proceed with any of these hardware replacement tasks. To complete these tasks, you must see both the documents.

Replacing components with no cluster data

The hardware you can replace that involve no cluster data includes:

- System memory
- Cooling fans
- Network Daughter Cards or Network Interface Cards
- PSUs

 **NOTE:** Use the hot-swap tasks in task 2 in this section (if only one PSU stops functioning).

1. In the *Nutanix Hardware Replacement Guide*, see the Failure of Components that do not Contain Cluster Data section and turn off the node for the relevant hypervisor.
2. In the *Dell XC430 Owner's Manual*, see the Installing and removing system components section and replace the failed component.
3. See the *Nutanix Hardware Replacement Documentation*, see the Failure of Components that do not Contain Cluster Data section, and then restart the node of the relevant hypervisor.

Replacing failed front HDD and SSD components that contain cluster data

To replace the failed front HDDs and SSDs that contain cluster data, do the following:

1. In the *Nutanix Hardware Replacement Documentation*, see the Data Drive Failure section and identify the failed HDD or SSD.
2. In the *Dell XC430 Web-Scale Converged Appliance Owner's Manual*, see the Installing and removing system components, HDDs, Removing a hot-swap hard drive, and Installing a hot-swap HDD sections.

 **NOTE:** New HDDs and SSDs being installed must have any foreign RAID configuration removed before being added to the system. Otherwise, they will not be recognized by the CVM.

3. See the *Nutanix Hardware Replacement Documentation* again, see the Completing Data Drive Replacement section and complete the replacement of the failed HDD or SSD.

Recovering system

For information about recovering your system, contact Dell Support.

Getting help

Contacting Dell

Dell provides several online and telephone-based support and service options. If you do not have an active internet connection, you can find contact information on your purchase invoice, packing slip, bill, or Dell product catalog. Availability varies by country and product, and some services may not be available in your area. To contact Dell for sales, technical assistance, or customer-service issues:

1. Go to **Dell.com/support**.
2. Select your country from the drop-down menu on the bottom right corner of the page.
3. For customized support:
 - a. Enter your system Service Tag in the **Enter your Service Tag** field.
 - b. Click **Submit**.The support page that lists the various support categories is displayed.
4. For general support:
 - a. Select your product category.
 - b. Select your product segment.
 - c. Select your product.The support page that lists the various support categories is displayed.

Locating Service Tag

Your system is identified by a unique Express Service Code and Service Tag number. This information is used by Dell to route support calls to the appropriate service provider.



Figure 5. Locating service tag

Quick Resource Locator

Use the Quick Resource Locator (QRL) to get immediate access to system information and how-to videos. This can be done by visiting **Dell.com/QRL** or by using your smartphone or tablet and a model

specific Quick Resource (QR) code located on your Dell system. To try out the QR code, scan the following image.



Figure 6. Quick Resource Locator